

12 Trouble Shooting

Problem	Possible Cause	Solution
The keyboard can not control the dome. There is no alarm linkage. There is no alarm output when changing the alarm input status. The alarm box doesn't work.	Bad connection of power cable.	Connect correctly.
	1A fuse break.	Change the 1A fuse.
	The Badness of power supply.	Change the power supply.
The keyboard can not control the dome, There is alarm linkage when changing the alarm input status.	The wrong setting of the keyboard baud rate. The Bad connection of the keyboard and alarm box .	Reset the keyboard baud rate, connect the keyboard and alarm box correctly.
	The bad connection of the dome and alarm box, The baud rate of dome and alarm box is not in accordance .	Connect the dome and alarm box correctly, Reset the dome baud rate.
There is alarm linkage, while the keyboard can not control the dome.	The Bad connection of the keyboard and alarm box. The baud rate of keyboard and alarm box is not in accordance.	Connect the keyboard and alarm box correctly, Reset the keyboard baud rate.
The keyboard can control alarm box, but can not control the dome, there is no alarm linkage.	The Bad connection of the alarm box and the dome. The baud rate of the dome and alarm box is not in accordance.	Connect the alarm box and dome correctly.
The keyboard can control the dome, but there is no alarm linkage.	Bad connection of the alarm input cable. or the connection cable open circuit.	Connect the alarm input cable correctly.

User Manual

8 in 2 out Alarm Box



Before use the product, please read this manual carefully.

Index

1 General	2
2 Main Features	2
3 Installation Diagram	3
4 Connection	4
5 Main Functions	5
6 DIP Switch Setting	5
7 Factory Default Setting	7
8 Keyboard Operation	7
9 Debugging	9
10 Installation	9
11 Technical Data	10
12 Trouble Shooting	11

11 Technical Data

Power Supply	$\geq 9V$ and $\leq 24V$ (AC or DC)
Power Consumption	$\geq 1W$
Alarm Output	0.4A, 125VAC; 2A, 30VDC
Weight	459g
Sending and Receiving Controlling Mode	RS485
Sending and Receiving Baud Rate	2400, 4800, 9600BPS
The Furthest Transferring Distance (0.5mm twisted-pair)	1200m
Environment Temperature	0~+50°
Dimension	200x120x75(mm)

9 Debugging

1. Do the first 5 steps according to 8 keyboard operation, the keyboard could conduct the operation to the dome. If it can not control, check each step carefully.
 - It is suggested that user check if the keyboard can control the dome without connecting to the alarm box.
 - Check if the power supply of the alarm box is connected to the alarm box correctly.
 - Check if the input and output of the RS485 is connected correctly.
2. If 1. is ok and the dome can be controlled by the keyboard, Set 8 presets and call the presets to ensure 8 presets have been set in the dome. First close the circuit of the N channel ($1 \leq N \leq 8$), open the circuit of the other channels, the dome should point to preset N. If there is no action with the dome, set all the alarm box input NO via keyboard, set the N alarm input channel corresponding to preset N ($1 \leq N \leq 8$), then set the alarm box arm.
3. Connect the sensors in all the channels to the alarm box. If the sensor is NC, Set the alarm box relay input NC after the connection and power on.
4. Test the system using the connected sensor. If there's no action with the dome, check if there's open circuit in connection lines and if the sensor works well.

10 Installation

1. If the system works well after the debugging, let all the cables across the cable aperture into the alarm box, screw the waterproof nut tightly.
2. Add a waterproof pat on the alarm box housing and screw tightly with screws to avoid leakage.
3. The cable aperture should be downward when fixing the alarm box.
4. User takes all the responsibilities if he doesn't install the alarm box according to the manual and result in the circuit damage for rain leakage.

1 General

The main function of the alarm box is alarm linkage. The alarm box can call the different presets quickly and automatically according to the different alarm signals. Connected with a dome camera, it can monitor different important places according to the sequence of the alarm signal acquired, realizing the dynamic spot video surveillance. The function of alarm linkage enables the system get the video information of alarm spot quickly. When there is alarm signal input, the alarm box can output two relay signals (NO/NC) for the user's reference.

2 Main Features

- IP66 waterproof design.
- Power supply 9V-24V AC/DC.
- RS485 controlling, 2400BPS, 4800BPS, 9600BPS baud rates selectable.
- Setting the alarm box ID (1-63) by setting dip switch.
- With the function of arm and disarm.
- Setting the attribute (NO/NC) of the alarm box relay input by keyboard.
- Setting the alarm input port number of the alarm box in accordance with the dome presets by keyboard.
- With the function of alarm spot memory.
- Setting the reset mode and interval time after alarming by keyboard.

3 Installation Diagram

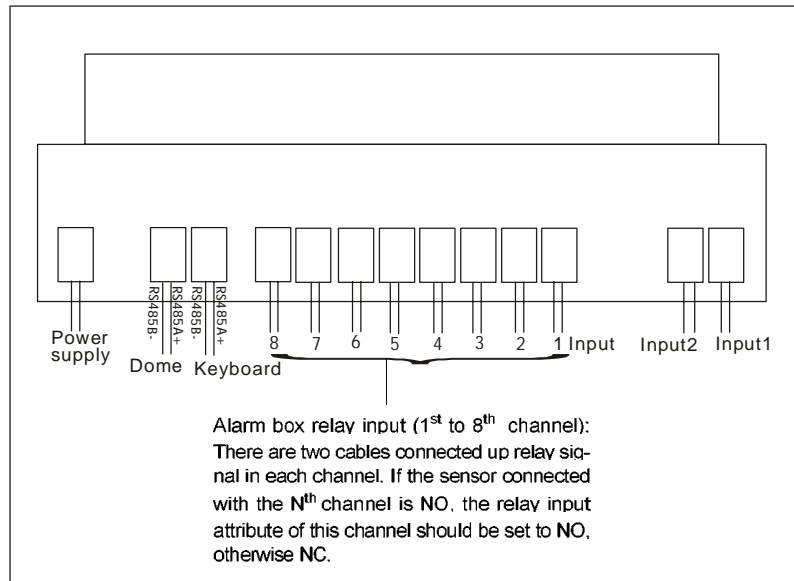
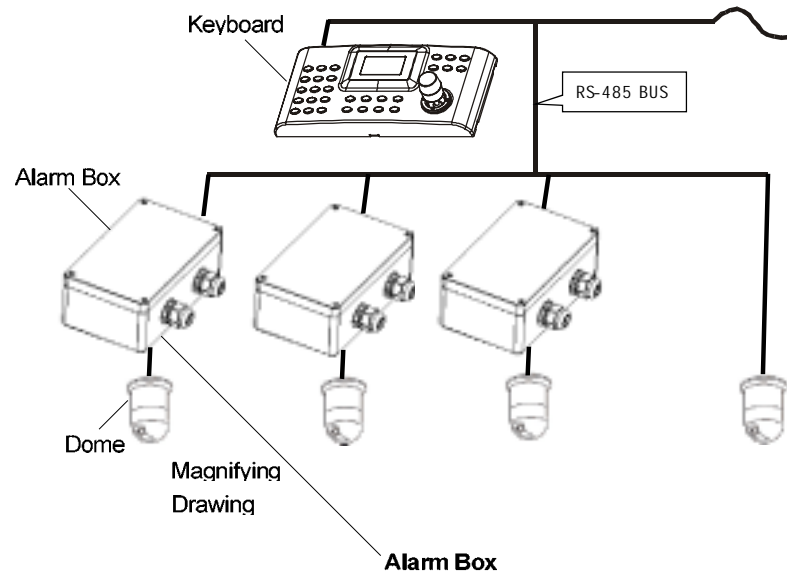

Operate as follows to set all the alarm input channel NO:

- 1) Input 0 for the Port No and press Enter.
- 2) Input 1 for the Status and press Enter.
- 3) Input 0 for the Preset and press Enter.
7. Arm, disarm and reset mode setting
 - 1) In the submenu of Alarm setup, input 2 to enter Alarm enable.
 - 2) Press 1 to switch from arm (Alarm: ON)/disarm (Alarm: OFF) state.
 - 3) Press "PREV", "NEXT" to plus or minus the value (0-50) of the reset (the value means the auto reset interval time). Press "DEL" key to set the value 0, which means manually reset. The auto-reset time is 5 times the value of the reset seconds. For example, if the value is 1, the auto-reset time is 5 seconds, if the value is 2, the auto-reset time is 10 seconds.
 - 4) Press Enter to confirm the setting.
8. Reset the alarm linkage.
 - 1) In the submenu of Alarm setup, input 3 to enter Alarm acknowledge. The screen will appear Input port No:
 - 2) Input 1-8 to reset the corresponding alarm input linkage. Input 0 and press ENTER to reset all the channels alarm linkage.

For example:

user can input 1 as well as 0, then press ENTER to reset the first alarm input channel.

7 Factory Default Setting

- The factory default alarm input and output attributes are NO.
- The 1-8 input channel of the alarm box is corresponding to the 1-8 preset of the dome. (Channel 1 to preset 1....)
- The alarm box ID is 1.
- The alarm box baud rate is 4800BPS.
- The alarm box is auto-reset, the auto-reset interval time is 5 sec.
- The alarm box is arm.

8 Keyboard Operation

1. Connect the alarm box with the keyboard and dome camera referring to the diagram 1.
2. Set the dome with manufacturer protocol and the same baud rate with the alarm box. The dome ID is random.
3. Set the alarm box ID.
4. Set the baud rate of the keyboard same to the alarm box.
5. When user conduct the operation to dome by keyboard, the dome ID number should be set the same as the ID number of the alarm box connected with the dome so as to fulfill the operation to the dome (For example, turn up, down, left, right, set preset and call preset.)
6. Set the attribute of the alarm input and the preset corresponding to the alarm input. Enter the submenu of Alarmbox I/O setup via keyboard. Port number: input alarm input channel number (1-8), input 0 to respond to all the 8 channels.

Status: The attribute of the alarm input channel, 1 for NO, 0 for NC.

Preset: The preset corresponding to the channel. (1-63)

For example:

The sensor connected to IN7 is NC in the normal status. If the sensor sends an open relay input to the alarm box in the alarm situation, operate as follows to make the dome point to the preset 7.

- 1) Input 7 for the Port No and press Enter.
- 2) Input 0 for the Status and press Enter.
- 3) Input 7 for the preset and press Enter.

4 Connection

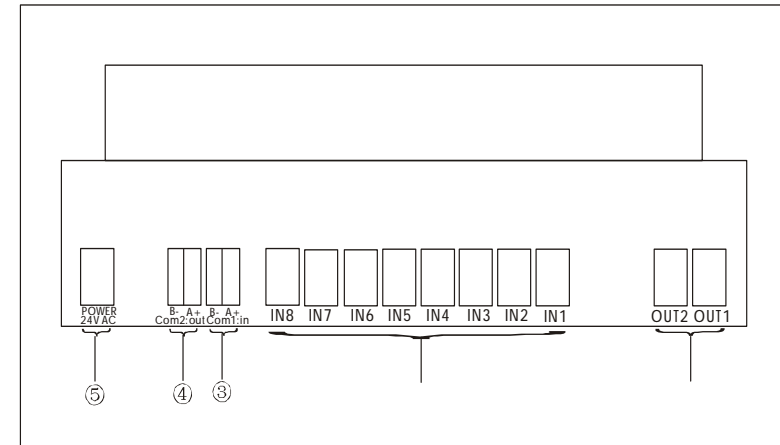

- ① **Alarm output:** There are two channels relay output, OUT1 and OUT2. Set NO or NC by setting the jumper SW1 and SW2 on PCB board.
- ② **Alarm input:** First make sure that the attribute of the sensor in each channel connected with alarm box input is NO or NC. The attribute of the sensor in each channel should be strictly in accordance with the alarm input attribute set in each channel. The first to eighth channel alarm input should be connected with the two terminals in IN1, IN2, IN3, IN4, IN5, IN6, IN7, IN8 accordingly. If the alarm input channels being used is less than 8, the two terminals of the unused alarm input channel should be short circuit to set the relay attribute NC. Accordingly the two terminals of the unused alarm input channel should be open circuit to set the relay attribute NO. For example, if there is only 7 alarm input channel being used the two terminals of the 8th alarm input channel should be short circuit or open circuit. According to the relay input attribute.
- ③ **RS485 input controlling cable:** connecting to the COM1 A+ and B- terminals. (The controlling signal is from keyboard.)
- ④ **RS485 output controlling cable:** connecting to the COM2 A+ and B- terminals. (The controlling signal is output to dome camera.)
- ⑤ **Power supply:** 9-24V AC/DC, Power \geq 1W, connecting to the two terminals in the POWER port. (There's no "+", "-".)

NOTE: Conducting the connection carefully to avoid misconnection as the connecting ports are jointed closely.

5 Main Functions

- User can set the alarm box arm or disarm via keyboard. When the alarm box is arm, besides accepting the operation to it and dome camera, the alarm box detects the input status all the time. Once there is alarm signal input, the alarm linkage will be activated, as well as the alarm output. When the alarm input signal disappears, the alarm linkage will keep on working until the alarm linkage is manually reset or automatically reset (via the keyboard controller). Only after the alarm linkage reset completely will the alarm output disappear automatically. When the alarm box is disarm, the alarm box will not respond to the alarm input.
- User can set the reset mode of alarm linkage and alarm output via keyboard. The alarm linkage and alarm output can be set manually as well as automatically. The auto-reset interval time can be set via keyboard.

6 DIP Switch Setting

As in the following diagram S1 is dip switch for setting alarm box ID and baud rate. The reset dip switch setting is not effective unless it is initialize again.

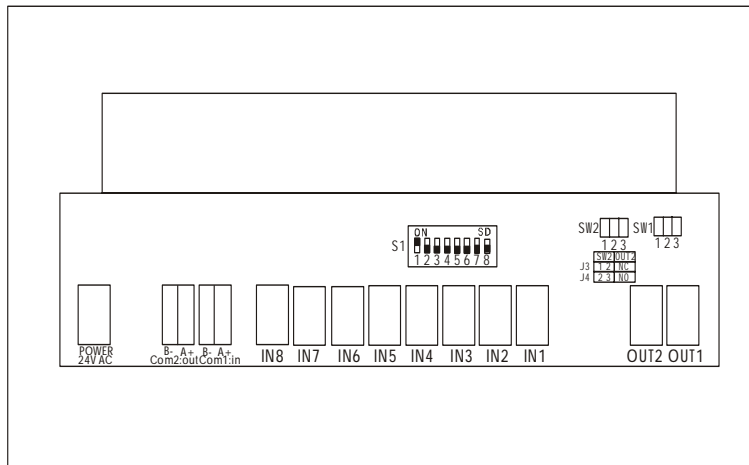

1 Setting the alarm box ID

The alarm box ID number (0-63) is set by setting the 1-6 bits of DIP switch. Detailed setting refer to the table below. The circle means the DIP switch setting should be "on".

ID	Switch number							
	ON							
0								
1	○							
2		○						
3	○	○						
4			○					
5	○		○					
6		○	○					
7	○	○	○					
8				○				
9	○			○				
10		○		○				
11	○	○		○				
12			○	○				
13	○		○	○				
14		○	○	○				
15	○	○	○	○				
16					○			
17	○				○			
18		○			○			
19	○	○			○			
20			○		○			
21	○		○		○			
22		○	○		○			
23	○	○	○		○			
24				○	○			
25	○				○	○		
26		○			○	○		
27	○	○			○	○		
28			○	○				
29	○		○	○	○			
30		○	○	○	○			
31	○	○	○	○	○			

ID	Switch number							
	ON							
32							○	
33	○						○	
34		○					○	
35	○	○					○	
36			○				○	
37	○		○				○	
38		○	○				○	
39	○	○					○	
40				○			○	
41	○			○			○	
42		○		○			○	
43	○	○		○			○	
44			○	○			○	
45	○		○	○			○	
46		○	○	○			○	
47	○	○	○	○			○	
48					○	○		
49	○				○	○		
50		○			○	○		
51	○	○			○	○		
52			○		○	○		
53	○		○		○	○		
54		○	○		○	○		
55	○	○	○		○	○		
56				○	○	○		
57	○				○	○	○	
58		○			○	○	○	
59	○	○			○	○	○	
60			○	○	○	○		
61	○		○	○	○	○		
62		○	○	○	○	○		
63	○	○	○	○	○	○		

2 Setting the alarm box baud rate

7, 8 bit of DIP switch is for setting the alarm box baud rate.

Baud rate	Switch number							
	ON							
2400bps								
4800bps							○	
9600bps								○